



Single Channel – CE Certified

Tunable Active  
Filter Instrument

**Description**

Frequency Devices' Models 900CT & 900BT instruments are single channel; 8-pole low-pass or high-pass, front panel tunable filter instruments. The controls allow the user to select a corner frequency between 0.1 Hz and 49.9 kHz with a resolution of 1:499 for each of the four selectable ranges.

The instrument exhibits an input impedance of 1 MΩ shunted by 47pF to a single ended signal source. When configured in the differential mode, the instrument has a common mode rejection ratio (CMRR), which exceeds 60dB; in this mode the instrument presents an input impedance of 2 MΩ's shunted by 47pF to a double-ended single source. Front panel gain control also enables the operator to select a gain factor of 0, 10, or 20dB.

Standard operational features include:

- 1) Adjustable Frequency Control
- 2) Differential Input Amplifiers
- 3) Adjustable Gain Control
- 4) Off-set Adjustment
- 5) Bypass Control
- 6) BNC Connectors for Signal I/O

The optional battery powered 900BT is particularly well suited to applications requiring isolation from an electrically noisy primary power source.

Compact size and manual rotary switch front panel controls make 900 instruments a popular, cost effective, easy-to-use solution for signal conditioning applications in the following areas:

- Anti-aliasing Filters
- Biomedical/Biotechnology Applications
- Data Recording/Playback
- Data Smoothing
- EKG/EEG Signal Filtering
- FDM/PCM Signal Filtering
- Medical Research
- Industrial Process Control
- Seismic Analysis
- Vibration Analysis



**Models**

- 900CT** Standard AC Powered
- 900BT** AC Powered, with battery option

**Available Low-Pass Filters:**

Part#	#Poles	Filter Type	Page
<b>900L8B</b>	8	Butterworth	6
<b>900L8L</b>	8	Bessel	6
<b>900L8E</b>	8, 6 zero	Elliptic, 1.77	6
<b>900L8EY</b>	8, 6 zero	Elliptic, 2.00	6
<b>900L8D80</b>	8, 6 zero	Constant Delay	7
<b>900L8D100</b>	8, 6 zero	Constant Delay	7

**Available High-Pass Filters:**

Part#	#Poles	Filter Type	Page
<b>900H8B</b>	8	Butterworth	8
<b>900H8E</b>	8, 6 zero	Elliptic, 1.77	8
<b>900H8EY</b>	8, 6 zero	Elliptic, 2.00	8

<b>Block Diagram</b>	2
<b>Front &amp; Rear panel descriptions</b>	4 & 5
<b>General Specifications:</b>	9
<b>Ordering Information</b>	10



BLOCK DIAGRAM

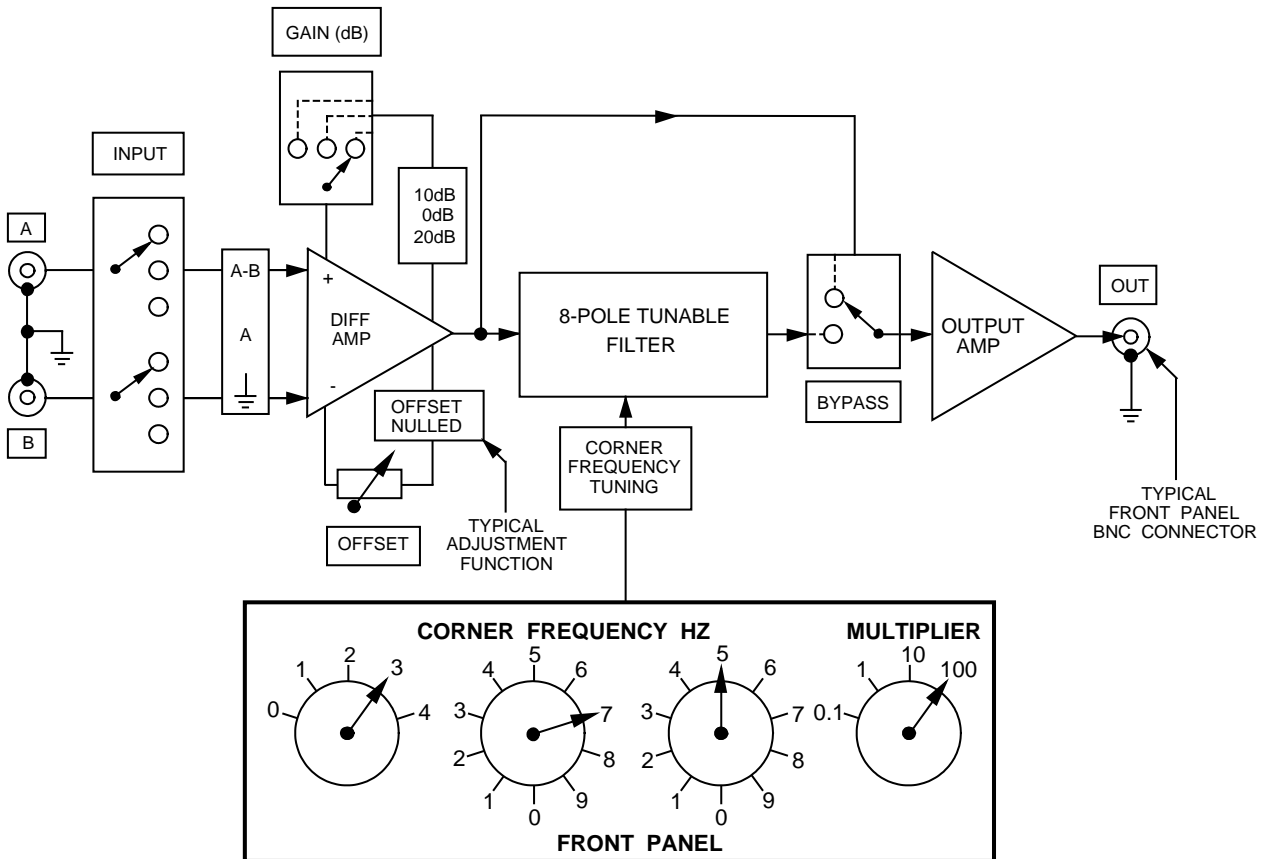



Single Channel – CE Certified

Initial Setup

Select desired operating voltage 115 V<sub>ac</sub> or 230 V<sub>ac</sub>. See note "Q" on Page 5.

Set the POWER ON/OFF Switch to ON. A continuously lit POWER lamp indicates proper internal DC voltages, an essential requirement for battery-powered models. Allow the instrument a three-minute warm-up period to achieve thermal equilibrium.

To perform initial adjustment and/or operational testing, set the remaining front panel controls as follows:

- a) The three base CORNER FREQUENCY switches and the MULTIPLIER to the desired corner frequency...
- b) The OFFSET control to approximately mid-range...
- c) The GAIN switch to the desired value...
- d) The BYPASS switch to OUT...
- e) The INPUT switch to ground (⊥).

Connect a dc-coupled oscilloscope, of vertical sensitivity 10mV/CM or better, or a digital voltmeter (DVM) to the instrument front panel BNC connector labeled OUT.

Set the OFFSET control for a zero-volt reading on the scope or DVM.

Subsequent changes of CORNER FREQUENCY and GAIN control settings will introduce a small dc output offset, which should be zeroed for critical applications.

Leaving all other controls unchanged, set the Input Switch to (A-B) and apply a 5Vdc signal simultaneously to input BNCs (A) and (B). The voltage measured at the OUT BNC should be 5 - 5 = 0 Vdc. This completes preliminary test and adjustment.

Corner Frequency Selection

To select a corner frequency, simply set the three CORNER FREQUENCY switches and the MULTIPLIER switch for the desired numerical value.

The CORNER FREQUENCY switch weightings follow standard decimal positional conventions.

The B, C and D switches combined can select base corner frequency values ranging from 1 to 499 Hz in 1 Hz steps with switch weightings as just described.

The accuracy of the corner frequency is improved by selecting the largest possible base frequency and down scaling by the MULTIPLIER. The greatest accuracy is obtained with the largest base 400, and the 0.1X MULTIPLIER switch setting.

Relative accuracy of selected 40 Hz actual corner frequency for different multiplier switch settings.

BASE FREQ			X MULT	RELATIVE TUNING ACCURACY
B	C	D	E	
4	0	0	0.1X	GREATEST
0	4	0	1X	LESS
0	0	4	10X	LEAST

The differential input

The instrument input utilizes a differential input amplifier to reject prevalent forms of electrical interference, while presenting desirable input characteristics to the signal source requiring filtering. The differential input configuration is ideal for measuring the difference between two values rather than the values themselves. Bridge circuits utilizing strain gages, thermocouples and a variety of other types of transducers generate differential full-scale output voltages in the order of millivolts that are often superimposed upon volt-level reference and noise levels.

The importance of CMRR

In actual system environments, each signal and power return conductor can generate an interference voltage proportional to the net conductor resistance and the electrical current level. Any such interference voltages appear as common mode signals to the amplifier, and are rejected as such.

Circuit model illustrating the relationship between a filter's differential input and amplifier and external signal and error sources.

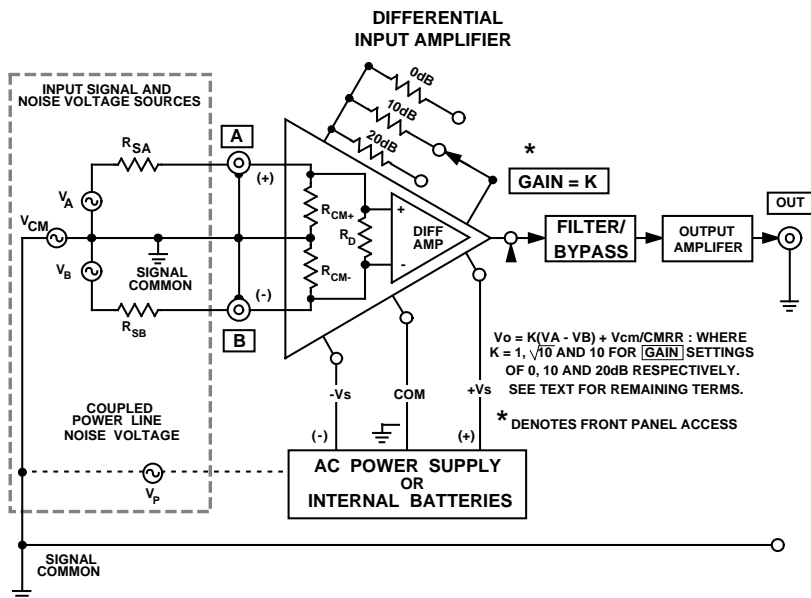



Location of Front Panel Terminals and Controls

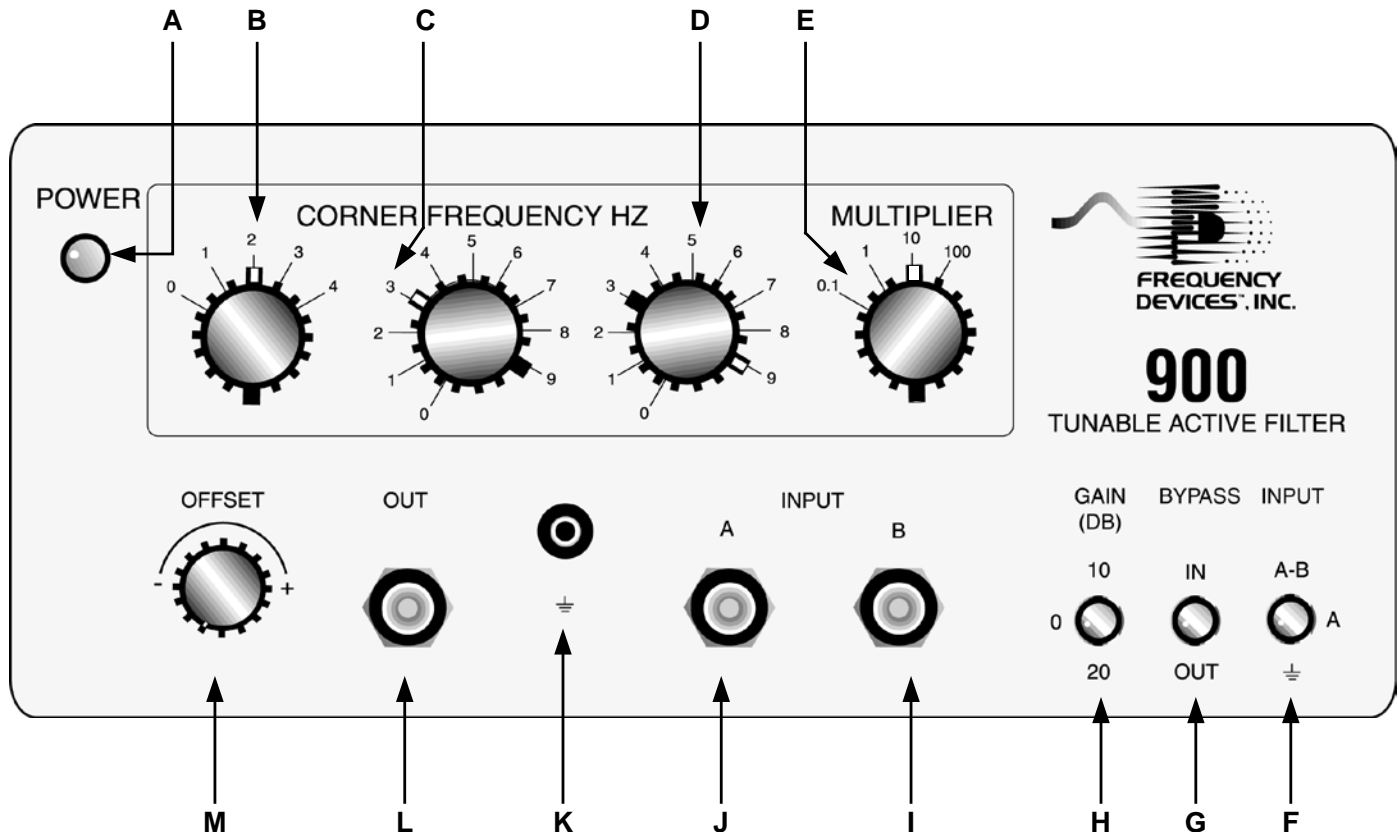

**A. POWER Status Lamp:** This red LED indicates whether or not the power to the analog filter circuitry of a Model 900CT/BT Series instrument is ON. With the power switch in the ON position, the LED glows continuously indicating internal DC power levels are correct. If LED does not light when power switch is in ON position, 1) reset instrument by cycling POWER switch OFF and ON, 2) Check line fuse.

For 900BT models only: If LED is flashing, recharge batteries, approximately 30 minutes of operation remains.

**B. CORNER FREQUENCY Selector Switch (0-400Hz):** This five position rotary switch selects the 100's digit of the corner frequency designator. The switch selectable values are 0, 100, 200, 300 and 400 in five discrete steps.

**C. CORNER FREQUENCY Selector Switch (0-90):** This ten-position rotary switch selects the 10's digit of the desired corner frequency between 0 and 90, in discrete increments of 10.

**D. CORNER FREQUENCY Selector Switch (0-9):** This ten position rotary switch selects the 1's digit of the desired corner frequency between 0 and 9 in discrete increments of 1.

**E. MULTIPLIER Selector Switch:** This four-position rotary switch multiplies by a factor of either 0.1, 1.0, 10 or 100, the aggregate value set on the 3 CORNER FREQUENCY selector switches. (B, C & D)

**F. GAIN Switch:** This three-position toggle switch selects an overall filter gain of 0, 10, or 20 dB.

**G. BYPASS Switch:** OUT and IN setting of this two position toggle switch routes the input signal to the internal filter or around it, respectively. E.g. OUT position - no Bypass, the signal passes through the filter. In either case, the gain switch remains operational.

**H. INPUT Switch:** This three position toggle configures the instrument for either differential inputs (A-B), a single-ended input (A), or input nulling ( $\perp$ ) which grounds both the (A) and (B) input terminals.

**I. & J. (A) and (B) Input Terminals:** This pair of shielded, female BNC connectors accept signal inputs (A) and (B). The instrument applies a non-inverting gain to input (A) and an equal but opposite inverting gain to input (B) while the GAIN switch sets the magnitude of differential gain to 0, 10, or 20 dB. The BNC shields have been internally connected to the instrument ground.

**K. GROUND ( $\perp$ ) Terminal:** This "Banana" type test jack provides neat and secure access to the internal ground. This terminal is a convenient junction for grounding external system and measurement instrumentation and/or apparatus.

**L. OUT Terminal:** This terminal is a female BNC connector. The shield on the BNC is internally connected to the instrument ground.

**M. OFFSET Adjust:** This adjustment is intended to zero the offset that results from the instrument's own circuitry and does not provide for wide range offset to remove dc input signals.



Location of Rear Panel Terminals, Controls and Labels

Model 900CT

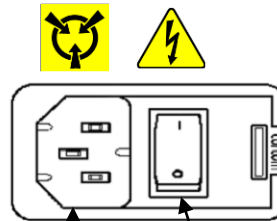
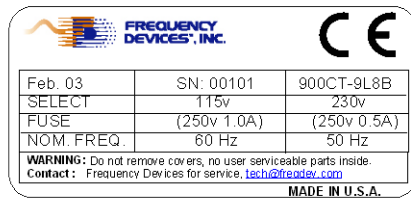

N

O

P

Model 900BT

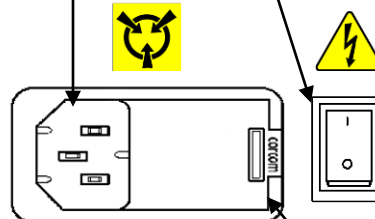
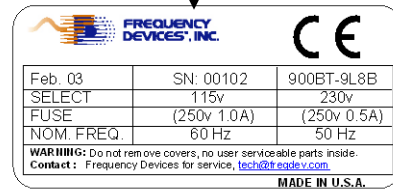

Q

**N. IDENTIFICATION LABEL:** This label identifies the Model number, filter type, serial number, date of manufacture, operating power limits and fuse requirements of the instrument.

**O. AC POWER CONNECTION:** Denotes plug and fuse location.

**P. POWER ON/OFF Switch:** Is a two-position toggle switch on the back panel that interrupts/completes the power circuit.

**Q. VOLTAGE Selector Module:** For 230 Vac operation, use a screwdriver blade to pry open the module door (entry point next to window), remove the red fuse cartridge, replace the 0.2 Amp, 250 V fuse with a 0.1 Amp, 250 Volt fuse, remove the shorting clip in the other leg and replace it with a second 0.1 Amp fuse. Turn the module 180 degrees, re-insert and close the module door. The numerals 230V will now show in the module window. Reverse procedure to change back to 115V.

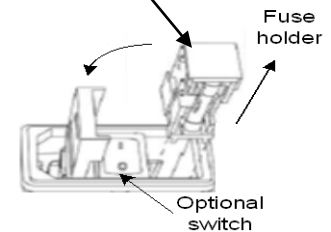



Model	900L8B		900L8L		900L8E		900L8EY	
<b>Filter Specifications</b>								
<b>Transfer Function</b>	8-Pole Butterworth		8-Pole Bessel		8-Pole, 6 zero Elliptic		8-Pole, 6 zero Elliptic	
<b>Range <math>f_c, f_r</math></b>	0.1 Hz to 49.9 kHz		0.1 Hz to 49.9 kHz		0.1 Hz to 49.9 kHz		0.1 Hz to 49.9 kHz	
<b>Theoretical Transfer Characteristics</b>	Appendix A Page 9		Appendix A Page 4		Appendix A Page 24		Appendix A Page 25	
<b>Tuning Resolution</b>	1 part in 499 within each decade		1 part in 499 within each decade		1 part in 499 within each decade		1 part in 499 within each decade	
<b>Passband Ripple</b>	0.0 dB		0.0 dB		±0.035 dB		-0.05 dB	
<b>Pass Band Voltage Gain (non-inverting)</b>	0 ± 0.1 dB typ. 0 ± 0.2 dB max.		0 ± 0.1 dB typ. 0 ± 0.2 dB max.		0 ± 0.1 dB typ. 0 ± 0.2 dB max.		0 ± 0.1 dB typ. 0 ± 0.2 dB max.	
<b>Stopband Attenuation</b>	48 dB/Octave		48 dB/Octave		-80 dB typ.		-100 dB typ.	
<b>Cutoff Frequency</b>	$f_c \pm 2\%$ max.		$f_c \pm 2\%$ max.		$f_c \pm 2\%$ max.		$f_c \pm 2\%$ max.	
<b>Accuracy</b>	±0.5% typ. ±2% max.		±0.5% typ. ±2% max.		±0.5% typ. ±2% max.		±0.5% typ. ±2% max.	
<b>Stability</b>	±0.01%/°C typ. ±0.02%/°C max.		±0.01%/°C typ. ±0.02%/°C max.		±0.01%/°C typ. ±0.02%/°C max.		±0.01%/°C typ. ±0.02%/°C max.	
<b>Amplitude</b>	-3 dB		-3 dB		-0.035 dB		-0.05 dB	
<b>Phase</b>	-360°		-182°		-323°		-419°	
<b>Filter Attenuation (theoretical)</b>	0.12 dB	0.80 $f_c$	1.91 dB	0.80 $f_c$	0.35 dB	1.00 $f_r$	0.05 dB	1.00 $f_r$
	3.01 dB	1.00 $f_c$	3.01 dB	1.00 $f_c$	3.01 dB	1.13 $f_r$	3.01 dB	1.06 $f_r$
	60.0 dB	2.37 $f_c$	60.0 dB	4.52 $f_c$	60.0 dB	1.67 $f_r$	60.0 dB	1.83 $f_r$
	80.0 dB	3.16 $f_c$	80.0 dB	6.07 $f_c$	80.0 dB	1.77 $f_r$	80.0 dB	2.00 $f_r$
<b>Total Harmonic Distortion @ 1 kHz</b>	<-90 dB typ.		<-90 dB typ.		<-90 dB typ.		<-88 dB typ.	
<b>Wide Band Noise (5 Hz – 2 MHz)</b>	200µV <sub>rms</sub> typ.		200µV <sub>rms</sub> typ.		250µV <sub>rms</sub> typ.		250µV <sub>rms</sub> typ.	
<b>Narrow Band Noise (5 Hz – 100 kHz)</b>	50µV <sub>rms</sub> typ.		50µV <sub>rms</sub> typ.		75µV <sub>rms</sub> typ.		75µV <sub>rms</sub> typ.	



Model	900L8D80		900L8D10	
<b>Filter Specifications</b>				
<b>Transfer Function</b>	8-Pole, 6 zero Constant Delay		8-Pole, 6 zero Constant Delay	
<b>Range fc</b>	0.1 Hz to 49.9 kHz		0.1 Hz to 49.9 kHz	
<b>Theoretical Transfer Characteristics</b>	Appendix A Page 21		Appendix A Page 22	
<b>Tuning Resolution</b>	1 part in 499 within each decade		1 part in 499 within each decade	
<b>Passband Ripple</b>	0.15 dB		0.15 dB	
<b>Pass Band Voltage Gain (non-inverting)</b>	0 ± 0.1 dB typ. 0 ± 0.2 dB max.		0 ± 0.1 dB typ. 0 ± 0.2 dB max.	
<b>Stopband Attenuation</b>	-80 dB typ.		-100 dB typ.	
<b>Cutoff Frequency</b>	fc ±2% max.		fc ±2% max.	
<b>Accuracy</b>	±0.5% typ. ±2% max.		±0.5% typ. ±2% max.	
<b>Stability</b>	±0.01%/°C typ. ±0.02%/°C max.		±0.01%/°C typ. ±0.02%/°C max.	
<b>Amplitude Phase</b>	-3 dB -306°		-3 dB -311°	
<b>Filter Attenuation (theoretical)</b>	3.01 dB	1.00 fc	3.01 dB	1.00 fc
	60.0 dB	3.08 fc	80.0 dB	4.45 fc
	80.0 dB	3.57 fc	100.0 dB	5.20 fc
<b>Total Harmonic Distortion @ 1 kHz</b>	<-90 dB typ.		<-88 dB typ.	
<b>Wide Band Noise (5 Hz – 2 MHz)</b>	200µV <sub>rms</sub> typ.		200µV <sub>rms</sub> typ.	
<b>Narrow Band Noise (5 Hz – 100 kHz)</b>	50µV <sub>rms</sub> typ.		50µV <sub>rms</sub> typ.	





Single Channel – CE Certified

8 Pole  
High Pass Filters

Model	900H8B	900H8E	900H8EY
<b>Filter Specifications</b>			
<b>Transfer Function</b>	8-Pole Butterworth	8-Pole, 6 zero Elliptic	8-Pole, 6 zero Elliptic
<b>Range fc, fr</b>	0.1 Hz to 49.9 kHz	0.1 Hz to 49.9 kHz	0.1 Hz to 49.9 kHz
<b>Theoretical Transfer Characteristics</b>	Appendix A Page 29	Appendix A Page 37	Appendix A Page 38
<b>Tuning Resolution</b>	1 part in 499 within each decade	1 part in 499 within each decade	1 part in 499 within each decade
<b>Passband Ripple</b>	0.0 dB	±0.035 dB	-0.05 dB
<b>Pass Band Voltage Gain</b> (non-inverting)	0 ± 0.2 dB to 100kHz 0 ± 0.5 dB to 120kHz.	0 ± 0.2 dB to 100kHz 0 ± 0.5 dB to 120kHz.	0 ± 0.2 dB to 100kHz 0 ± 0.5 dB to 120kHz.
<b>Power Bandwidth</b>	120 kHz	120 kHz	120 kHz
<b>Stopband Attenuation</b>	48 dB/Octave	-80 dB typ.	-100 dB typ.
<b>Cutoff Frequency</b>	fc ±2% max.	fc ±2% max.	fc ±2% max.
<b>Accuracy</b>	±0.5% typ. ±2% max.	±0.5% typ. ±2% max.	±0.5% typ. ±2% max.
<b>Stability</b>	±0.01%/°C typ. ±0.02%/°C max.	±0.01%/°C typ. ±0.02%/°C max.	±0.01%/°C typ. ±0.02%/°C max.
<b>Amplitude Phase</b>	-3 dB	-0.035 dB	-0.5 dB
<b>Phase</b>	-360°	-323°	-419°
<b>Filter Attenuation</b> (theoretical)	80.0 dB   0.31 fc 60.0 dB   0.42 fc 3.01 dB   1.00 fc 0.00 dB   2.00 fc	80.0 dB   0.56 fr 60.0 dB   0.60 fr 3.01 dB   0.88 fr 0.03 dB   1.00 fr 0.00 dB   2.00 fr	100.0 dB   0.50 fr 80.0 dB   0.55 fr 3.01 dB   0.94 fr 0.03 dB   1.00 fr 0.00 dB   2.00 fr
<b>Total Harmonic Distortion @ 1 kHz</b>	<-88 dB typ.	<-88 dB typ.	<-88 dB typ.
<b>Wide Band Noise</b> (5 Hz – 2 MHz)	400µV <sub>rms</sub> typ.	400µV <sub>rms</sub> typ.	500µV <sub>rms</sub> typ.
<b>Narrow Band Noise</b> (5 Hz – 100 kHz)	100µV <sub>rms</sub> typ.	100µV <sub>rms</sub> typ.	150µV <sub>rms</sub> typ.





**Input Characteristics**

Input Impedance:	
Differential	2 MΩ Shunted by 47pF
Single Ended	1 MΩ Shunted by 47pF
Input Voltage:	
Linear Differential*	20V p-p (Gain Set at 0 dB)
Max Safe Differential	Any Continuous Value between ±100V
Max Safe Common Mode	Any Continuous Value between ±100V
Bias Current	30 pA typ.; 175 pA max.
Common Mode Rejection ratio with 2kΩ source unbalance and 0 dB Gain	> 60dB, DC to 50kHz

**Output Characteristics**

Full Power Bandwidth**	DC to 600kHz
Related Output	10V p-p for R <sub>L</sub> = 50Ω 20V p-p for R <sub>L</sub> = 2kΩ
Short Circuit Output Current	±100 mA continuous
Output Protection	±200 mA without damage (Short Circuit to Ground Only)
Output Impedance	50 Ω
Offset Voltage	Adjustable to Zero at Front Panel (Range ±500mV dc)

**Power Supply**

AC Line Power Operation	<b>900CT</b> <b>900BT</b>	10 Watts max. 15 Watts max.
-------------------------	------------------------------	--------------------------------

**Voltage Frequency Range-Rear Panel:**

115 V	105 to 125Vac @ 50/60Hz
230 V	210 to 250Vac @ 50Hz
Fuse	115 V=0.2 Amp., 230 V = 2X-0.1 Amp.

**Battery Operation (900BT)**

Time for full Charge	10 – 12 hours
Battery Life	Approx. 500 Charge/Discharge Cycles
Battery Charger	Automatic Uninterruptible
Charge Status Indicator (Front Panel)	3 Status Levels
Battery Operation	6 Hours typ.

**Temperature**

Operating Temperature:	0 °C to +50 °C
Storage Temperature:	-25 °C to +70 °C

**Mechanical**

Dimensions	3.7"H x 8.66"W x 10.6"D 9.4cmH x 22.0cmW x 27.0cmD
Weight	<b>900CT</b> <b>900CT</b> 3.5 lbs; 0.157 kgs 4.9 lbs; 0.219 kgs
Case Material	ABS plastic
Color	Light Gray

\* Signal plus common mode voltage cannot exceed 20V peak to peak for a linear output.

\*\* Output characteristics of input amplifier with filter in BYPASS mode.



**A. AVAILABLE MODELS**

- |          |   |
|----------|---|
| 1. 900CT | Standard AC powered model <sup>1</sup>              |
| 2. 900BT | AC powered with battery powered option <sup>1</sup> |

**FILTER TRANSFER FUNCTIONS AVAILABLE <sup>2</sup>**

**B. LOW-PASS**

- |                |    |          |                                       |
|----------------|----|----------|---------------------------------------|
| BUTTERWORTH    | 1. | 900L8B   | 8-pole                                |
| BESSEL         | 2. | 900L8L   | 8-pole                                |
| ELLIPTIC       | 3. | 900L8E   | 8-pole, 6 zero elliptic, 1.77, 80 dB  |
|                | 4. | 900L8EY  | 8-pole, 6 zero elliptic, 2.00, 100 dB |
| CONSTANT DELAY | 5. | 900L8D80 | 8-pole, constant delay 80 dB          |
|                | 6. | 900L8D10 | 8-pole, constant delay 100 dB         |

**C. HIGH PASS**

- |             |    |         |                                       |
|-------------|----|---------|---------------------------------------|
| BUTTERWORTH | 7. | 900H8B  | 8-pole                                |
| ELLIPTIC    | 8. | 900H8E  | 8-pole, 6 zero elliptic, 1.77, 80 dB  |
|             | 9. | 900H8EY | 8-pole, 6 zero elliptic, 2.00, 100 dB |

**ORDERING INFORMATION**

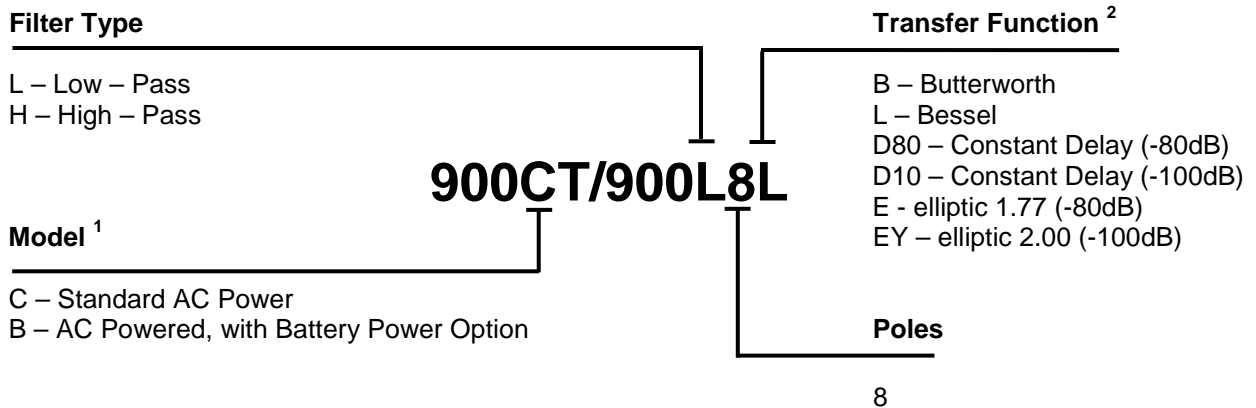

**NOTE:**

1. See page 5, item "Q" Voltage selector Module. At time of shipment, Voltage is pre-selected in the 115 V<sub>AC</sub> position. For 230 V<sub>AC</sub> operation, this module must be rotated 180 degrees and an additional fuse must be added.
2. All filters tunable from 0.1 Hz to 49.9 kHz.

We hope the information given here will be helpful. The information is based on data and our best knowledge, and we consider the information to be true and accurate. Please read all statements, recommendations or suggestions herein in conjunction with our conditions of sale, which apply, to all goods supplied by us. We assume no responsibility for the use of these statements, recommendations or suggestions, nor do we intend them as a recommendation for any use, which would infringe any patent or copyright. IN-00900CT/BT-00